

The HPS Hydraulic Generator for Fixed Displacement Hydraulic Systems

The HPS hydraulic generator is a purpose built onboard hydraulic generator solution, designed specifically for the integration into existing hydraulic circuits. The unit shown above is suited to an extensive range of construction machinery that operate with fixed displacement pumps.

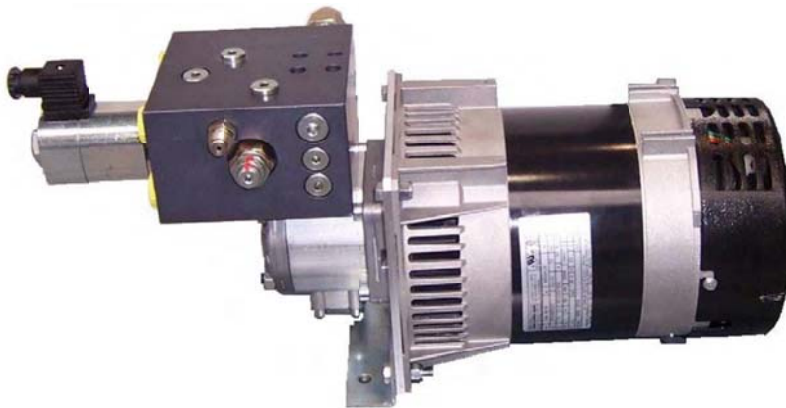

The manifold incorporates all of the required valves to allow the generator to operate without the need for any other component parts. It incorporates a 12v diverter valve, pressure relief valve and a pressure compensated flow control. To install, simply reconnect the existing pressure line from the pump into P1, reconnect it back out of P2 and connect a tank return line from T.

The unit operates only when the solenoid is energised, this then diverts flow away from the normal functions and through the flow control valve to provide a regulated flow through the gear motor to the alternator. Excess flow is returned to tank. When the solenoid is de-energised flow passes directly into P1 and out of P2 which simply acts as a bypass to the functions.

The electrical connections involved provide a 12v supply to the coil on the solenoid valve via a toggle switch.

It is recommended that the AC power cable from the alternator is connected to an RCBO, which is a combined Earth Leakage Circuit Breaker and Miniature Circuit Breaker. This provides protection both to the operator in the event of an earth fault and to the unit in the event of overload. It should be installed as close to the output cable of the alternator as possible in order to ensure that the power cable running through the equipment is protected throughout its entire length. The generator can be mounted in any convenient location, is fully weather proof and can be mounted vertically if required.

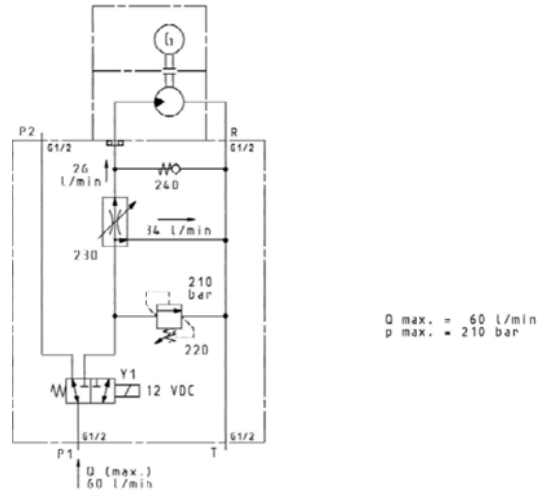

Units can be supplied in a range of outputs from 2 – 12 kVa, single or three phase, 50 and 60 Hz as well as a range of welder / generators. One of the key advantages of the HPS hydraulic generator is that within this range the manifold and valves are common on all units. The units are virtually maintenance free and come with a two year warranty as standard on parts and labour.

